

LTX-51 BMS Gateway for Toshiba air-conditioning units

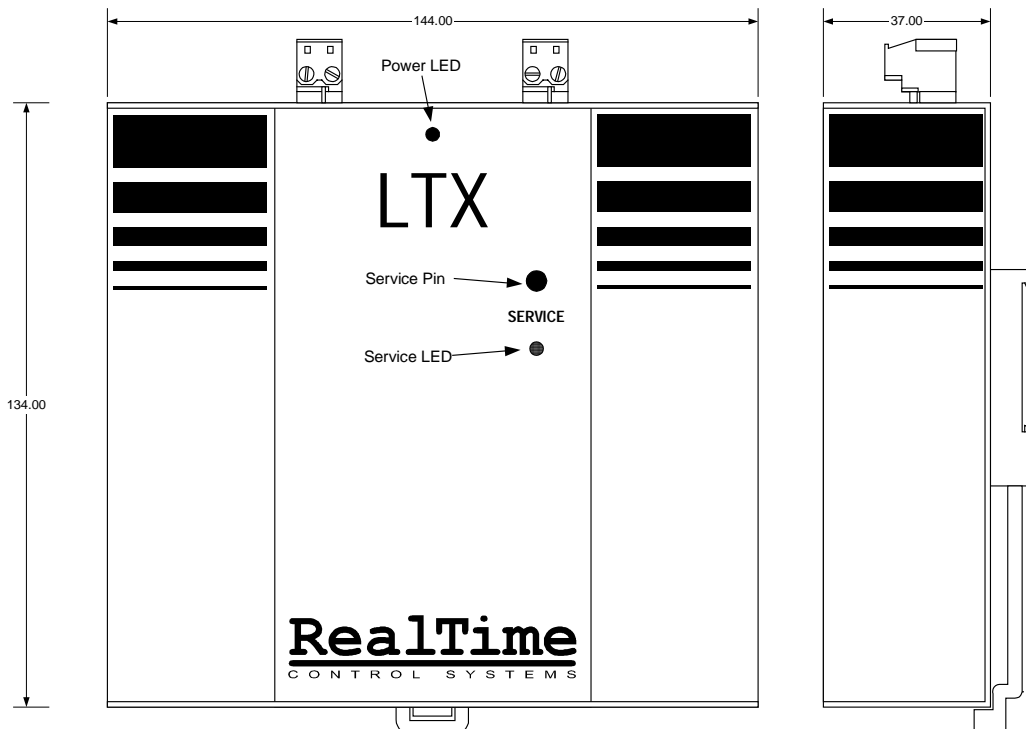

Description

The LTX-51 is a Modbus BMS interface for integrating R22 and R407C Toshiba RAV range air-conditioning units with BMS systems such as Cylon. The gateway removes the need for hardwired connections to BMS input and outputs and replaces them with a networked connection. All functionality available using hardwired inputs is available, in addition specific fault-codes from the Toshiba system are reported as BMS alarms and can be received by any connected BMS supervisor either on site or remotely. Furthermore the return-air and heat-exchanger temperatures from each unit are also fed back for control and monitoring purposes. The gateway can handle up to 16 independent zones, removing the need for up to 80 hardwired i/o points on the BMS, and can report fault codes from each of the indoor units connected.



Dimensions (mm)

LTX-51 Iss1.00

1 Introduction

1.1 LTX-51 Features

- Modbus standard interface via RS-232 port
- Independent control of up to 16 air-conditioning units
- Software configurable Master/Slave groupings
- No BMS I/O points used
- Reporting of fault codes for each of the 16 indoor units and attached outdoor units.
- Programmable default operating conditions
- Feedback of measured temperatures from each indoor unit – no need for separate space temperature sensors
- Co-ordinated BMS and local user control with keypad lockout facilities
- Remote unit reset and fault clearance.
- Compatible with other LTX-Modbus products
- Extendible to multiple Modbus devices using only a single serial port.

1.2 System Description

The LTX-51 allows BMS control and monitoring of up to 16 Toshiba RAV units without the need for hardwired points. As illustrated in Figure 1 this integration is achieved by a combination of a RealTime LTX-51 and a Toshiba LG1. The LTX-51 is also compatible with the RealTime LRC-LG interface, and a single LTX interface can be configured to interface to an LG1 and one or more LRC-LG interfaces to allow control of different combinations of air-conditioners.

The LTX-51 provides an RTU mode Modbus RS-232 connection for interfacing to BMS with compatible Modbus interfaces. Consult the RealTime *LTX-Modbus Engineering Guide* for specific interfacing details. This guide also covers the use of multiple LTX products through a single interface to provide additional functionality such as LonWorks SNVT interfacing to the BMS. This datasheet describes the LTX-51 version 1.00. This is compatible with the LTX-Modbus firmware version 1.00.

The control of the air-conditioning equipment is achieved via the Toshiba LG1 interface, one of

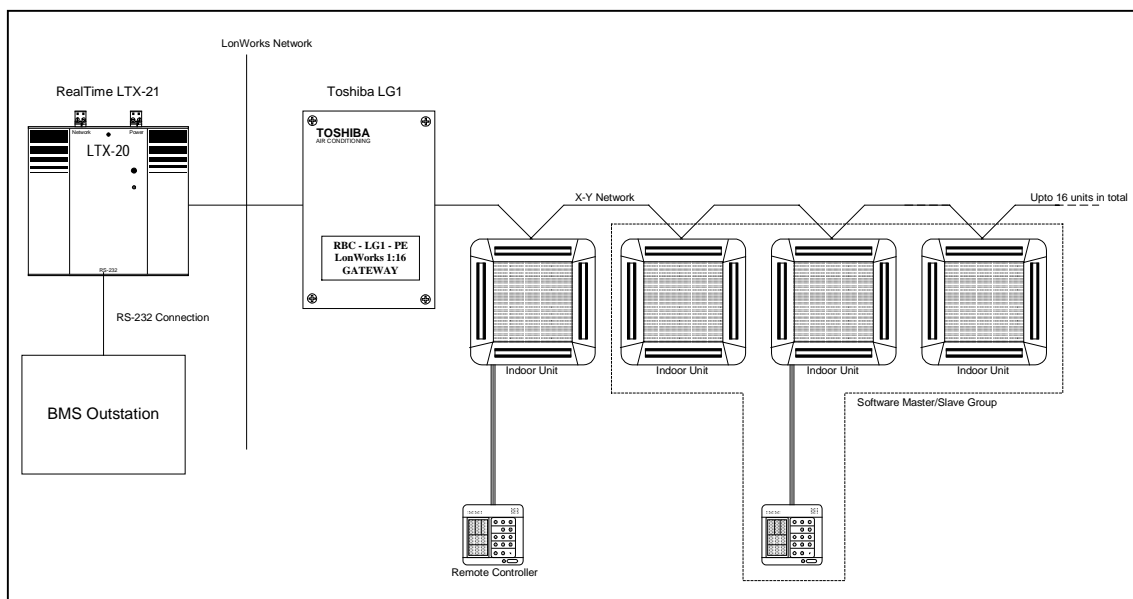

Figure 1. LTX-51 Topology

which is required for every 16 indoor units. Both the LTX-51 and Toshiba LG1 are based on LonWorks® technology which allows the devices to be directly connected via a single free-topology network. In order to enable communications between the LTX-51 and the LG1 interfaces it is necessary to 'bind' the devices together using a suitable LonWorks Network Management tool. An LTX-51 is normally required for each LG1 in the system, multiple LTX-51 interfaces can be networked together and accessed via a single RS-232 interface.

Interfaces required for connecting to the LTX-51 are shown in the following table of Toshiba products.

	RAS - xxx	RAV - Heatpump	RAV – Cooling only
R22 – Series 0 to 3	X	LRC-LG	LRC-LG
R407C – Series 4	X	Toshiba LG1	LG1/LRC-LG*

*NOTE: Series 4 Cooling-Only *split* units do not have X-Y connections and are therefore not compatible with the LG1. However 'Cooling-only' units in VRF applications are actually 'heat-pump' indoor boards (with the -H) in the unit code, these *are* compatible with the LG1 as they have X-Y terminals.

The LTX-51 datasheet focuses on integration of the LTX-51 with the Toshiba LG1. For information about using the LRC-LG consult the datasheet available at www.realttime-controls.co.uk. **Note that temperature feedback is not available from the LRC-LG.**

Larger systems can be controlled by either using multiple LTX-51 and LG1 pairs, or by using the Toshiba WG1 in conjunction with the RealTime LTX-52 interface which supports the control of up to 64 units from a single interface. See the RealTime LTX-52 datasheet for more information.

With Toshiba Modular Multi a separate LG1 is required for each outdoor unit. The LTX-51 can manage up to two LG1 interfaces (and hence two modular multi systems) with a total of 16 units across the two LG1s. The LTX-52 can handle up to 4 modular multi outdoor units using the Toshiba WG1. Note that in Modular Multi systems only the Return Air temperature is available from the indoor units, the Heat Exchanger temperature will appear as a constant value of 72°C.

1.3 Functionality

Each indoor unit requires the following information to be set to determine its operation.

- Setpoint
- Fan speed
- Run Mode
- Louver Control
- On/Off state
- Keypad Enable State

Values for these states are usually determined in the BMS control strategy according to time-of-day, external conditions etc. The BMS writes these values into the LTX-51 using standard Modbus registers. The LTX-51 converts the values into *network variables* compatible with the LG1 LonWorks interface. The LG1 feeds back the return-air temperature, heat exchanger temperature and fault code from each unit. The measured temperatures can be read by the BMS for monitoring and control purposes. Each indoor unit can be placed in a Master/Slave grouping, allowing multiple 'soft' zones and the ability to rezone through software.

The LTX-51 monitors the faults codes of each of the indoor units and provides various different values accessible by the BMS; including time filtered fault codes, codes classified as critical or non-critical faults, and common fault statuses. These fault codes are briefly summarised at the end of this datasheet.

The LTX-51 also provides a 'fail-safe' mode of operation that places all of the air-conditioners in a user defined default mode should communications with the BMS fail for any reason.

2 LTX Engineering

This section contains details of the various engineering features available for configuring unit control and fault code and temperature monitoring. Section 0 describes the steps required to commission and test and installation.

The LTX-51 uses standard engineering conventions described in the *LTX-Modbus Engineering Guide Issue 1.00*. The LTX-51 contains a number of standard features contained in all RealTime LTX-Modbus products, the engineer should be familiar with these features prior to engineering the LTX-51.

The Modbus Application Profile (MAP) in Section 5 provides references to all registers in the LTX-51 application. The core register set for the RealTime LTX-Modbus are also accessible, the register profile for these is in the *LTX-Modbus Engineering Guide*.

2.1 Modbus Configuration

The engineering guide referred to above provides details on configuring the Modbus Address and serial port communications parameters. Multiple LTX interfaces are accessible from any LTX serial port by allocating each LTX interface a separate Modbus address. Both the Modbus device and the serial communication parameters can be configured using either a Modbus engineering tool or a LonWorks engineering tool.

2.2 Unit Control

2.2.1 Unit Operation Basics

The LTX-51 can control up to 16 A/C units via LG1 and LRC-LG interfaces. The data for each unit is contained in a single register column. The High Registers 1 to 16 correspond to the 16 units. For example the setpoint knobs for units 1 to 16 are in holding registers **H[1,21]** to **H[16,21]**, the return air temperatures for units 1 to 16 are in input registers **IP[1,14]** to **IP[16,14]**.

A Unit has six control values that define its operation. These are:

Name	Min	Max	Notes
Setpoint	18	29	Degrees Centigrade
Fan speed	0	3	0=AUTO,1=LOW, 2= MED, 3=HIGH
Run mode	0	3	0=AUTO, 1=HEAT, 2=FAN_ONLY,3=COOL
Louver	0	1	0=OFF, 1=ON
On/Off	0	1	0=OFF, 1=ON
Keypad Enable	0	1	0=CENTRAL CONTROL, 1=LOCAL KEYPAD

Generally most of these values are 'knob' values that are only adjusted by the user through the BMS User Interface. Some values are scheduled by the BMS control strategy, most commonly the On/Off state, and in some applications the setpoint and keypad enable status change according to time of day, PIR inputs, outside air temp, optimum start schedules etc.

Knobs in the LTX interface are currently stored in EEPROM to make them *Non-Volatile* i.e. to ensure their values persist across power downs and resets. This causes a problem if the values are scheduled from control strategy because EEPROM a limit to the number of

changes that can be made before it stops storing new data. A 'Knob' can be used if the value is to remain constant, or if the value will be changed infrequently. In this case the BMS user interface can directly reference the LTX register associated with the knob.

For scheduled values such as setpoint and OnOff which may change frequently and are written to from points within the master BMS a duplicate set of *volatile nodes* are available for each unit. A set of configuration switches for each zone determine for each control value whether the Non-Volatile Knob or the Volatile node value are used to control the unit. For example the setpoint for unit 1 can either be sourced from the non-volatile knob in $H[1,21]$ or the volatile node $H[1,1]$. The configuration switch $H[1,11]$ controls this, setting $H[1,11]=0$ selects the volatile value, setting $H[1,11]=1$ selects the non-volatile knob. In many applications only the On/Off state is scheduled from the BMS and requires setting to the volatile setting.

Example: An application requires for Unit #1 that the OnOff state and the Setpoint are scheduled from the control strategy. The remaining unit control parameters are adjustable knobs.

Hence the NV configuration switches are set so that Non-Volatile knobs are used for Fanspeed, RunMode, Louver and Keypad state, and volatile nodes are used for the Setpoint and OnOff parameters.

These operating settings are only relevant to units configured as *Master Units*, slave units have no independent settings and take their settings from the master.

2.3 Unit Master/Slave Groupings

Each unit has a *Master Unit* register $H[1-16,41]$ that defines whether the unit is active, and whether the unit is a master or a slave. Initially all units have this register set to zero, meaning that they are inactive. Activating a unit is achieved by setting the master unit register to a value between 1 and 16 which defines the master of the unit. Setting the master unit register to its own unit number configures the unit as a master, otherwise it is a slave.

Assigning a non-zero value to the Master Unit Register of a particular unit causes that unit to receive control commands and for fault and temperature feedback to be monitored from the unit.

In most applications units are grouped so that several units receive a common set of operating conditions. This also allows multiple units to be controlled from a single remote controller keypad if local control is being used. With the LTX-51 grouping is performed in software, rather than by hardwiring. One unit within a group is assigned as the *group master*, the rest of the units are designated as *group slaves*. If remote controllers are in use then the group master will be the unit with the remote controller.

Example: A 10 unit system is split into three groups; Group 1=Units 1 to 4. Group 2=Units 5 to 7. Group 3 = Units 8 to 10.

The lowest address of each group is assigned as the group master for each group.

Group 1: $H[1,41]=1$, $H[2,41]=1$, $H[3,41]=1$, $H[4,41]=1$

Group 2: $H[5,41]=5$, $H[6,41]=5$, $H[7,41]=5$

Group 3: $H[8,41]=8$, $H[9,41]=8$, $H[10,41]=8$

Configuring the groups within the LTX means that no hardwiring is required to create group control and allows rezoning to be performed simply by altering the Master Unit registers.

2.3.1 Commission Command

When commissioning a system it is often useful to activate all units in order to discover what devices are on the network and to set all units to certain operating conditions. In addition the BMS interface may not be fully operational and it is therefore desirable to operate units from the LTX in a stand-alone fashion.

The *commission* command register `H[112,2]` is used to activate or disable all units from a single command. The following commands are available

Command	Action
<code>H[112,2]=0</code>	Disables all units by setting each master unit register to zero
<code>H[112,2]=1</code>	Enables all units as a single group by setting the master unit to unit 1
<code>H[112,2]=2</code>	Enables all units as stand-alone masters, allowing each unit to be controlled individually.

Units can then be controlled from the active control fields of the unit master (the non-volatile knobs by default).

By examining the readback data for each unit it is possible to determine those units that are active. Those units that are active will return temperatures and normal Fault Code values.

2.3.2 Block Commands

The block update register `H[204,1-255]` provides a fast method for setting values for all units simultaneously. In the LTX-51 the block write register copies a value written to register `H[204,X]` to all unit registers `H[1-16,X]`. Hence the command `H[204,41]=8` sets the Master unit for all units to unit number 8. Similarly the command `H[204,11]=0` switches the active setpoint of all units to the volatile node value.

2.3.3 Unit Data Simulation

The simulate command update register `H[112,3]` allows unit data to be simulated even if no units are attached to the system, or if the LTX is not bound to the A/C interfaces. This is useful when proving the BMS to LTX data transfer, it is also useful for testing and demonstrating specific alarm features. The following commands are available

Command	Action
<code>H[112,3]=0</code>	Clears fault simulation
<code>H[112,3]=1</code>	Assigns random fault code and random RA and HE temperatures to each active unit
<code>H[112,3]=X X>1</code>	Assigns each unit fault code 'X' (decimal value) and random RA and HE temperatures to each active unit

The simulated fault codes and random temperatures remain in place until fault simulation is cleared or the LTX is reset. Note that with the command `H[112,3]=X` it is possible to assign any fault code including 255 (No Fault) so it is possible to simulate faults occurring and clearing.

Each unit has simulate register `H[1-16,52]` which is set by the simulate command. The user can also write to each units simulate register separately in order generate specific unit faults. Again when commissioning is complete these registers should be cleared by Simulate Clear, Reset or setting the individual registers to zero.

2.3.4 Grouping across LTX interfaces Using Register Bindings

Using the register bindings in the LTX Common Registers it is possible to create master/slave groups across two or more LTX interfaces. The register bindings also allow more sophisticated links to be made such as linking on/off states or setpoints to other LonWorks devices. See the *LTX-Modbus Engineering Guide* for detailed examples.

2.3.5 Multiple LG1 Interface Handling

In cases where Modular Multi systems are employed it is necessary to use a separate LG1 interface for each Modular-Multi system. The LTX-51 supports up to two LG1 interfaces with the restriction that there is a total of 16 or fewer units across the two systems (See the LTX-52 datasheet for applications with more than 16 units and/or more than 2 interfaces). The LonWorks Engineering section on page 17 describes the necessary steps for binding two LG1s to the LTX.

The systems connected to each LG1 should be configured using the recommended AI-Network addressing procedure so that in each system unit addresses begin at address number 1. In order for both the units in both systems to be visible within the LTX it is necessary to 'remap' the secondary LG1 addresses within the LTX.

For example, given a Primary LG1 with 10 units and a Secondary LG1 with 6 units, the first 10 units registers within the LTX are allocated to the Primary LG1. It is necessary to allocate the free unit registers 11 to 16 to the Secondary LG1 units. The *Secondary Interface Handover* register $\boxed{H[11,4]}$ defines the unit number where the Secondary Interface units should begin. The default value is zero, meaning Secondary unit is not active, by setting the value between 1 and 16 the Secondary units will start at the defined value. If the value is set to 1 then the primary interface will now become inactive and up to 16 Secondary units will be visible. In the example above the register value would be set to 11, so that $\boxed{H[11,*]}$ will control the settings for Secondary unit number 1, $\boxed{H[12,*]}$ will control the settings for Secondary unit number 2 and so on.

As with the standard configuration the Master Unit register $\boxed{H[1-16,41]}$ for each active unit must be configured. Master/slave groups can be created across the Primary and Secondary interfaces if desired.

2.4 Local/Central Control

The LTX-21 can be used to operate the air-conditioning units in conjunction with local user interfaces (generally called 'remote' controllers). This type of control is more complex as it requires co-ordination to ensure that the BMS does not override user demands.

Combined BMS/local control generally involves allocating times during which the user has control of the system, and times during which the BMS has control of the system. Each unit has a *Keypad Enable* control value, if this value is 0 then the unit is controlled by the settings in the LTX and the unit keypad is locked out. Setting keypad enable to 1 unlocks the keypad and locks out control from the LTX.

Example: *a meeting room is held off during unoccupied hours and during occupied hours local control is enabled but the system is kept off. If the meeting room becomes occupied during defined occupancy hours the occupants can turn the system on until the occupancy time defined in the BMS is ended, at which time local control is locked out and the system is turned off by the BMS.*

When under local control, any units that are operating as group slaves respond to the keypad settings of the master zone. If a keypad is attached to a slave it will always remain locked out

as the slave unit takes its settings from the master unit. Hence it is important that units with keypads attached are defined as masters in the LTX.

The group master/slave definitions create 'soft' groups of units that operate under a single set of operating conditions under both central control and from a single keypad attached to the defined by the group master.

2.4.1 Unit Defaults and Timeout options

The communications link between the LTX and the BMS is a critical link because the desired operating conditions of the units are sourced from the BMS. If the link is disconnected or the BMS cannot communicate for any reason then the air-conditioning units may remain off or may remain in an undesirable state such as morning pre-heat. To prevent this causing significant problems the LTX monitors the communications and if they fail can place the units into default override conditions defined within the LTX. The default registers `H[111,21-26]` contain the default operating conditions for all units.

Unit control within the LTX-51 can originate from several different sources. There are conditions where only some unit updates fail whilst others remain live. Two different timeout mechanisms are available. The Core Modbus Timeout register `H[211,5]` monitors all Modbus read/write operations to the LTX and sets a global fail flag if no Modbus communications are observed for a specified time. If this timeout is enabled (value>0) then a timeout will lead to all units being placed into default conditions. Additionally a Unit Register Update timeout option is available `H[111,2]`; a non-zero setting causes register writes to each unit to be monitored, if no updates to a single unit are observed for the specified time then that unit is placed into default operating conditions. This facility is useful in applications where groupings are placed across more than one LTX and ensures that slaves that are dependent on a master in another LTX will enter default conditions if the other LTX stops communicating.

2.5 Unit Readback Data

Readback data from each unit is available in the input register array `I[1-16,*]`. This contains the raw data readback from the unit as well as various additional read-only data relating to unit operation.

2.5.1 Temperature Feedback

The LTX monitors the return air (RA) temperature and heat-exchanger (HE) temperature from each indoor unit. These values are available in the Input Registers in two different formats.

The first format of RA and HE in `I[1-16,12]` and `I[1-16,13]` respectively are the raw data formats returned by the A/C units. This format is equivalent to the LonWorks *SNVT_temp_p* data format. The register is a signed 16 bit number that represents the temperature multiplied by 100. E.g. a temperature of 18.5 degrees C is represented as 1850.

The second format of RA and HE in `I[1-16,14-15]` and `I[1-16,16-17]` respectively are IEEE 32 bit floating point representations stored in two registers. Reading this data using Modbus master is achieved by configuring the read of a 32 bit Float, and referencing the lower register (14 for RA, 16 for HE). The modbus master will automatically read both registers and format the resultant data correctly.

2.5.2 Raw Fault Code Feedback

The fault codes for each air-conditioning unit are monitored, this data is available in several different formats. Within the LTX the fault codes are available as a number in the range 0 to 255 (decimal). The convention for presenting Toshiba fault codes is to use *hexadecimal*

formatting. This formatting must be performed by the BMS supervisor. The established method for presenting the no-fault conditions is the value 255 (decimal), this is 'FF' in hexadecimal but is usually presented as in the form of two dashes as '—' in a fault display. Mappings between decimal and hexadecimal fault codes are provided on page 22 of this datasheet.

The *readback* faultcode provides the current code being read back from the unit. This is available as a number `I[1-16,22]` or as a digital status 'IsReadBack Fault' `I[1-16,21]`, where a value of 1 represents a fault.

A record of the last fault condition for each units is stored in the 'Last Fault Code' register `I[1-16,25]`, which contains the last readback fault code classified as a fault.

It is strongly recommended that the decimal values are not displayed to the user as the use of hexadecimal values is well established and displaying the decimal values is likely to lead to confusion between values displayed by the BMS and values given in service manuals.

2.5.3 Filtered Fault Code Feedback

To help the user manage the alarm generation process the LTX offers several tools to reduce alarm volume and minimise the occurrence of non-essential alarms. Two methods are used; *alarm classification* classifies each fault as either critical or non-critical, *alarm time filtering* provides transient alarm filtering for critical and non-critical faults. The Filtered Fault Code is available in `I[1-16,24]`.

The configuration switches `H[111,11]` and `H[111,13]` activate the reporting of critical and non-critical alarms respectively to the Filtered Fault Code register. The most common use of these switches is to switch-off the reporting of non-critical faults.

The configuration values `H[111,12]` and `H[111,14]` configure the alarm time in minutes for filtering critical and non-critical alarms respectively. A value of zero means no time filtering is applied. When a time filter is active, any change in a fault code causes a timer to be started, the new fault code is only reported once the timer has finished. If the fault changes again before the timer has finished the timer is restarted. Hence the timer filter prevents faults that occur for less than the duration of the timer to be reported, therefore removing transient faults. Generally the alarm time filters will be set to report critical alarms rapidly, with e.g. 5 minute filter applied, whilst non-critical faults will have timer of several hours applied to filter out false alarms.

2.5.4 Alarm Classification

Several faults may be classified as critical or non-critical depending on the application. Configuration options are available to alter the default classifications of these faults.

The fault codes '0C' and '0d' report faults on the temperature sensors TA and TC. These are classified as critical faults by default. Setting the configuration switch `H[111,16]` to a value of 1 changes this classification to non-critical.

A second option controls the classification of 'B7' faults. These are generated by master units with slaves connected on the A-B-C connections. If any of the slave units has any type of fault code the master will generate a B7 fault. The B7 fault is assumed to be critical, however it may be that slaves generate significant numbers of non-critical faults that appear as critical B7 faults. In this case the option is available to reclassify the B7 fault as non-critical by setting the configuration switch `H[111,16]` to a value of 1.

2.5.5 Unit Communications Faults

The LTX gathers unit data by sending queries for each unit. Failure to respond or mismatches between required and actual unit operating conditions can indicate particular problems. When a unit fails to respond to a poll query the poll failure count `I[1-16,26]` is incremented. When the failure count reaches 8 consecutive failures then communications with the unit are considered to have failed, and the unit fault code is set to '99' and the Unit Comms OK register `I[1-16,27]` is set to zero.

The readback unit settings data is also monitored and compared with the desired settings (when under BMS control). If the readback settings differ from the desired settings then the Unit Update OK register `I[1-16,28]` is set to zero.

Problems with unit communications or readback errors are indicative of a variety of different configuration problems. Consult the troubleshooting guide on page 24 for possible solutions.

2.5.6 Common Fault Registers

As an alternative to monitoring each unit fault status individually the LTX-51 also makes *common fault* registers available that indicate if *any* active unit is in a fault condition. Critical and Non-Critical Fault conditions are reported separately for both filtered and unfiltered fault codes. The registers are as follows

Register	Contents
<code>I[151,1]</code>	Common Non-Critical Fault - Unfiltered
<code>I[151,2]</code>	Common Critical Fault – Unfiltered
<code>I[151,3]</code>	Common Non-Critical Fault – Filtered
<code>I[151,4]</code>	Common Critical Fault – Filtered

2.5.7 Feedback of Heartbeat and Alarm Bits

The LTX-Modbus *Common Registers* provide a heartbeat bit `I[251,1]` that can be used by the Modbus Master to generate an alarm on the BMS side if the communications link is broken. The LTX-Modbus Engineering Manual provides details on how to create alarms based on the heartbeat bit.

3 Commissioning

3.1 Toshiba Installation and Commissioning

3.1.1 RealTime LRC-LG

For installations involving the RealTime LRC-LG consult the LRC-LG datasheet. In general LRC-LGs can be treated as additional LG1 interfaces when performing LonWorks engineering as their functional profile is very similar. Additional configuration is required to set the address ranges for each LRC-LG to ensure that there is a unique LTX unit address for each air-conditioning unit attached to the interfaces bound to the LTX-51. The LTX-51 can support a maximum of 16 LRC-LGs with a total of 16 units.

3.1.2 Toshiba LG1 Interface

Details and requirements for setting up the Toshiba air-conditioning units for use with the Toshiba LG1 are provided in the pull-out on page 21. This information should be provided to the air-conditioning installer to ensure that the units are configured correctly for operation with an LG1.

Note: The installation and configuration required for LTX-21/LG1 control of Toshiba A/C units is different from the standard method of installation. All units should be installed as 'masters', any master/slave groupings are created by engineering the LTX-21. If units are hardwired as slaves then fault and temperature information will not be available. In addition software grouping provides the greatest flexibility because any future re-zoning can be achieved purely through software.

Once the air-conditioning units are installed and operational the LG1/LTX-21 interface must be engineered using a LonWorks engineering tool to create the linkage between the two devices. This engineering is described in detail in the LonWorks Engineering section on page 17.

3.1.3 Modular-Multi Interfaces

With Toshiba *Modular-Multi* series of air-conditioners the LG1 interfaces via a single connection to the outdoor unit rather than directly connecting to each indoor unit. A separate LG1 interface is required for each outdoor unit. The LTX-51 can support a maximum of two LG1 interfaces with a total of 16 units connected to the two LG1s.

3.1.4 Toshiba WG1 Interface

The Toshiba WG1 interface supports up to 64 indoor units. The WG1 is compatible with the RealTime LTX-52 Modbus interface. Refer to the LTX-52 datasheet for more information.

3.2 LTX Installation and Commissioning

Perform necessary LonWorks engineering as outlined in the LonWorks Engineering section on page 17 of this manual. Then follow the standard LTX-MODBUS installation procedures to set-up the various core functionalities of the LTX including configuring the serial port and setting the Modbus address of the unit. Once the standard configuration has been set-up the LTX-51 application can then be engineered.

3.2.1 LTX-51 Engineering Steps

The following checklist outlines the steps to set-up the LTX for a typical application. Section 2 provides details of the engineering required.

Modbus Configuration

- Configure the LTX Serial Port
- Assign a unique Modbus address to the LTX

Groupings

- Activate and assign Active Units to Master/Slave Groupings
- Create External Bindings for groups spanning more than one LTX

BMS Control

- Assign selected NV Switches to Volatile values for each Group Master

Unit Defaults

- Set Unit Defaults
- Set Unit and Modbus Timeout options

Alarms

- Set Critical and Non-Critical Alarm Activation and Filter options
- Set fault code 'B7' and '0C','Od' Classification options

BMS engineering

- Create register mappings writing BMS controlled settings
- Create register mappings reading filtered Alarm values
- Create register mappings reading unit temperatures

Consult the *LTX-Modbus Engineering Guide* for details on engineering standard features such as heartbeat monitoring and locking engineering registers.

4 Remote Maintenance Procedures

The LTX-21 allows the A/C units to be managed remotely and allows initial response and investigation of faults to be performed remotely. This removes the need for site attendance simply to reset units and ensures that site maintenance only occurs for urgent faults that have already been investigated. The following sections outline what tools are available for observing, diagnosing and clearing faults remotely.

4.1 Identifying Units with Faults

Examine registers `I[1-16,22]` to identify units with active faults. The registers `I[1-16,25]` will show the last recorded fault for any unit that is currently clear.

4.2 Fault Diagnosis

The fault codes provide an indicator to the type of problem that is occurring (refer to the Toshiba Service manual for details). However often there may be several possible causes for a particular problem. For example an '09' fault may be caused by low refrigerant charge or incorrect sensor positioning. The severity of a fault can be determined by the length of time a fault occurs and the frequency of the alarms and this information can also be used to distinguish different reasons for a particular fault code to occur.

The return air temperature and heat-exchanger temperatures can also be used as diagnostic aids. The heat-exchanger temperature will show the temperature of the coil and whether the unit is actually actively cooling or heating. Units can be temporarily overridden and the setpoints modified so that the unit can be forced into heating or cooling to determine if the unit is working correctly. The heat-exchanger and return air temperatures can be written back into the BMS so that plots can be set up if there is a need to observe a unit's behaviour over a period of hours or days.

4.3 Fault Clearing

The fault clearance command `H[112,1]` can be used to reset all indoor units and clear any unit faults (except 99 faults). Note it may be sometimes necessary to send the command several times before all units reset. Clearing faults allows false alarms and occasional stopping faults to be distinguished from permanent faults. E.g. high temperature or pressure lockouts on outdoor units may simply be due to operation on an exceptionally hot day or high load. Resetting the unit will allow the unit to restart and reduces the urgency of the problem unless there is a fundamental problem in which case the unit will stop again.

5 Modbus Application Profile

5.1 LTX-51 Application Holding Registers

Name:	Unit Holding Registers	HOLDING 1-16
Type:	Read/Write	
Description:	Configuration and control data for Unit #x referenced by high register x	

Low Reg	Hex Reg	Dec Reg	Name	Type	Coil Alt	Eng Lock	Default	Min	Max	Notes
1	0x0101	257	Setpoint Node (Vol)	U16			18	18	29	
2	0x0102	258	Fan speed Node (Vol)	U16			0	0	3	
3	0x0103	259	Run mode Node (Vol)	U16			0	0	3	
4	0x0104	260	Louver Node (Vol)	U16	✓		0	0	1	
5	0x0105	261	On/Off Node (Vol)	U16	✓		0	0	1	
6	0x0106	262	Keypad Enable Node (Vol)	U16	✓		0	0	1	

Low Reg	Hex Reg	Dec Reg	Name	Type	Coil Alt	Eng Lock	Default	Min	Max	Notes
11	0x010B	267	Setpoint Switch NV Enable	U16	✓	✓	1	0	1	
12	0x010C	268	Fan speed Switch NV Enable	U16	✓	✓	1	0	1	
13	0x010D	269	Run mode Switch NV Enable	U16	✓	✓	1	0	1	
14	0x010E	270	Louver Switch NV Enable	U16	✓	✓	1	0	1	
15	0x010F	271	On/Off Switch NV Enable	U16	✓	✓	1	0	1	
16	0x0110	272	Keypad Enable Switch NV Enable	U16	✓	✓	1	0	1	

Low Reg	Hex Reg	Dec Reg	Name	Type	Coil Alt	Eng Lock	Default	Min	Max	Notes
21	0x0115	277	Setpoint Knob (NV)	U16			18	18	29	
22	0x0116	278	Fan speed Knob (NV)	U16			0	0	3	
23	0x0117	279	Run mode Knob (NV)	U16			0	0	3	
24	0x0118	280	Louver Knob (NV)	U16	✓		0	0	1	
25	0x0119	281	On/Off Knob (NV)	U16	✓		0	0	1	
26	0x011A	282	Keypad Enable Knob (NV)	U16	✓		0	0	1	

Low Reg	Hex Reg	Dec Reg	Name	Type	Coil Alt	Eng Lock	Default	Min	Max	Notes
41	0x0129	297	Master Unit	U16		✓	0	0	16	Set to non-zero to activate. If set to own address then unit is a Master, otherwise it is a Slave to the unit defined by this register

Low Reg	Hex Reg	Dec Reg	Name	Type	Coil Alt	Eng Lock	Default	Min	Max	Notes
51	0x0133	307	Clear Filter	U16	✓	✓	0	0	1	Set to 1 to clear filter alarm from unit (manually reset to zero)
52	0x0134	308	Test Fault Code	U16		✓	0	0	255	Set to non-zero to overwrite readback code and generate user defined fault for this zone (note 'decimal' equivalent of code must be entered)

Name:	LG1 Configuration Holding Registers	HOLDING 111
Type:	Read/Write	
Description:	Configuration parameters for device operation	

Low Reg	Hex Reg	Dec Reg	Name	Type	Coil Alt	Eng Lock	Default	Min	Max	Notes
1	0x6F01	28417	LG1 Poll rate (secs)	U16		✓	5	1	255	Controls the rate of unit updates/queries the LG1
2	0x6F02	28418	LG1 Register Update timeout seconds	U16		✓	0	0	255	0 = Disabled, >0, Timeout applied to each register. If no write occurs to register from any source, after <i>timeout</i> seconds the units is set to the default settings.
3	0x6F03	28419	Local Handover Count	U16		✓	1	0	255	Number of additional updates prior to handover to local control
4	0x6F04	28420	Secondary Interface Handover Unit	U16		✓	0	0	16	0 = Disabled, Activates secondary LG1 handling.

											Value defines the first zone of the secondary LG1
--	--	--	--	--	--	--	--	--	--	--	---

Low Reg	Hex Reg	Dec Reg	Name	Type	Coil Alt	Eng Lock	Default	Min	Max	Notes
11	0x6F0B	28427	Critical Alarm reporting Enabled	U16	✓		1	0	1	Value of 1 activates reporting of critical alarms
12	0x6F0C	28428	Critical Alarm Filter Time (mins)	U16			0	0	1440	If non zero then time filtering is applied to critical faults
13	0x6F0D	28429	Non-Critical Alarm reporting Enabled	U16	✓		1	0	1	Value of 1 activates reporting of non-critical alarms
14	0x6F0E	28430	Non-Critical Alarm Filter Time (mins)	U16			0	0	1440	If non zero then time filtering is applied to non-critical faults
15	0x6F0F	28431	B7 as non-critical	U16	✓		0	0	1	0 assigns B7 as a critical fault, 1 assigns B7 as a non-critical fault
16	0x6F10	28432	0c,0d as non-critical	U16	✓		0	0	1	0 assigns 0c,0d as critical faults, 1 assigns as a non-critical fault (default=1)

Low Reg	Hex Reg	Dec Reg	Name	Type	Coil Alt	Eng Lock	Default	Min	Max	Notes
21	0x6F15	28437	Default Setpoint	U16			21	18	29	
22	0x6F16	28438	Default Fan speed	U16			0	0	3	
23	0x6F17	28439	Default Run mode	U16			0	0	3	
24	0x6F18	28440	Default Louver	U16	✓		0	0	1	
25	0x6F19	28441	Default On/Off	U16	✓		1	0	1	
26	0x6F1A	28442	Default Keypad Enable	U16	✓		0	0	1	

Name:	LG1 Application Command Holding Registers	HOLDING 112
Type:	Read/Write	
Description:	Registers allowing specific commands to be performed	

Low Reg	Hex Reg	Dec Reg	Name	Type	Coil Alt	Eng Lock	Default	Min	Max	Notes
1	0x7001	28673	Reset All A/C Unit Faults	U16	✓		0	0	1	Sends a reset to all units to reset/clear faults
2	0x7002	28674	Commission Units	U16		✓	0	0	2	0 Disables all Units, 1 Sets all units to Unit 1 Master, 2 Sets all units to be Stand-Alone Masters
3	0x7003	28675	Simulate Faults	U16		✓	0	0	255	0 Disables Fault Simulation, 1 Assigns Random Faults (and Temps), >2 assigns that value to the fault codes (and rand temps)

5.2 LTX-51 Application Input Registers

Name:	Unit Input Registers	INPUT 1-16
Type:	Read Only	
Description:	Read-only unit settings and readback data from Unit #x referenced by high register x	

Low Reg	Hex Reg	Dec Reg	Name	Type	Coil Alt	Notes
1	0x0101	257	Readback Setpoint	U16		
2	0x0102	258	Readback Fan speed	U16		
3	0x0103	259	Readback Run mode	U16		
4	0x0104	260	Readback Louver	U16	✓	
5	0x0105	261	Readback On/Off	U16	✓	
6	0x0106	262	Current Keypad Enable	U16	✓	Not Readback value on Lg1

Low Reg	Hex Reg	Dec Reg	Name	Type	Coil Alt	Notes
11	0x010B	267	Filter Alarm	U16	✓	
12	0x010C	268	Return Air Temp (SNVT_temp_p)	S16		Scaled by 100
13	0x010D	269	Heat Exch Temp (SNVT_temp_p)	S16		Scaled by 100
14	0x010E	270	Return Air Temp (float)	F32		32 bit float – High Word IP[1-16,14-15]
15	0x010F	271		F32		32 bit float – Low Word
16	0x0110	272	Heat Exchanger Temp (float)	F32		32 bit float – High Word IP[1-16,16-17]
17	0x0111	273		F32		32 bit float – Low Word

Low Reg	Hex Reg	Dec Reg	Name	Type	Coil Alt	Notes
21	0x0115	277	IsReadback Fault	U16	✓	0=No Fault, 1=unfiltered fault
22	0x0116	278	Readback Fault Code	U16		Unfiltered fault code 0..255

23	0x0117	279	IsFiltered Fault	U16	✓	0=No Fault, 1=filtered fault
24	0x0118	280	Filtered Fault Code	U16		Filtered fault code 0..255
25	0x0119	281	Last Fault Code	U16		Last fault that occurred for this unit 0..255
26	0x011A	282	Poll Failure Count	U16		
27	0x011B	283	Unit Comms OK	U16	✓	0 if communications failure with this unit
28	0x011C	284	Unit Update OK	U16	✓	0 if readback settings are different from control settings.

Low Reg	Hex Reg	Dec Reg	Name	Type	Coil Alt	Notes
31	0x011F	287	Current Setpoint	U16		
32	0x0120	288	Current Fan speed Knob	U16		
33	0x0121	289	Current Run mode Knob	U16		
34	0x0122	290	Current Louver Knob	U16	✓	
35	0x0123	291	Current On/Off	U16	✓	
36	0x0124	292	Current Keypad Enable	U16	✓	

Name:	Common Status Input Registers	INPUT 151
Type:	Read Only	
Description:	<i>Global Status values for common faults conditions etc</i>	

Low Reg	Hex Reg	Dec Reg	Name	Type	Coil Alt	Notes
1	0x9701	38657	Common Non-Critical Fault (unfiltered)	U16	✓	
2	0x9702	38658	Common Non-Critical Fault (filtered)	U16	✓	Time and class filtered common fault
3	0x9703	38659	Common Critical Fault (unfiltered)	U16	✓	
4	0x9704	38660	Common Critical Fault (filtered)	U16	✓	Time and class filtered common fault

5.3 LTX-Modbus Standard Profile

The LTX-51 operates using LTX-Modbus v1.00 core firmware. Consult the *LTX-Modbus Engineering Guide v1.00* for details of these registers and their usage.

6 LonWorks Engineering

This section discusses the engineering requirements for binding the LTX-51 and the Toshiba LG1. For applications using the RealTime LRC-LG interface consult the LRC-LG datasheet.

The first step in configuring an LTX-51 and the LG1 interfaces is to perform the necessary LonWorks engineering to bind the devices together. Any suitable LonWorks network management tool can be used. Details of the LTX-51 functional profile are provided in this section.

Firstly, install the LTX-51 in the engineering tool either by pressing the service pin on the front or using the LTX command `H[212,2]`. If no copy of the external interface file is available then upload this from the device. Add the LTX-51 function block to the project.

Next install the LG1 into the tool and import the interface. Not all network inputs and outputs are necessary for configuration. For clarity it is recommended that only those necessary for configuration are added to the function block.

For a standard application with a single (Primary) LG1 the following network variables should be bound

LTX-51	Direction	LG1 Primary
nvoUnitSettings[0]	⇒	nviUnitSettings2
nvoQuery[0]	⇒	nviQuery
nvoClearance	⇒	nviClearance
nviIndoorData[0]	⇐	nvoIndoorData

Note that the LG1 contains two Unit Settings network variables, only nviUnitSettings2 should be bound to.

For applications where two LG1s are in bound to the LTX-51, the secondary LG1 is bound as follows

LTX-51	Direction	LG1 Secondary
nvoUnitSettings[1]	⇒	nviUnitSettings2
nvoQuery[1]	⇒	nviQuery
nvoClearance	⇒	nviClearance
nviIndoorData[1]	⇐	nvoIndoorData

The LTX-51 uses an addressing method to send and receive data with the air-conditioning interface. The units that are controlled by the LTX-51 are determined by which zones are configured as active within the LTX-51. Note that it is important to set the LG1 configuration parameter nciNumUnits equal to the maximum indoor unit address. If the value is less then certain units will not be controlled and it may lead to unpredictable behaviour. If in doubt set nciNumUnits to 16.

Once the binding for each zone is complete the LonWorks engineering of the system is complete, however it is recommended the engineering tool is left attached to the network, or is reattached after commissioning is complete as this will allow LTX-51 configuration parameters to be saved in the project database for backup purposes.

LTX-51 Functional Profile

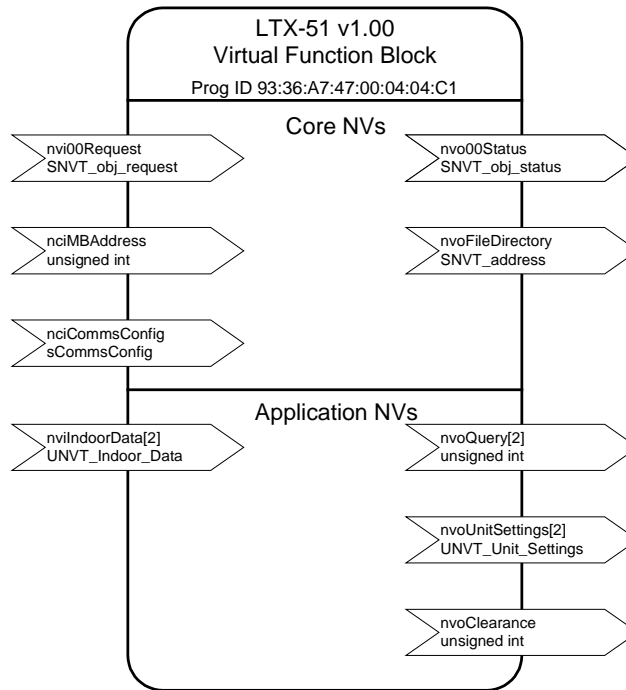

The LTX-51 functional profile is shown above. The following table gives a summary for each network variable.

NV Index	Name	In/Out	Type	Description
0	nvi00Request	In	SNVT_obj_request	
1	nvo00Status	Out	SNVT_obj_status	
2	nvoFileDirectory	Out	SNVT_address	File pointer to configuration data
3	nciMBAAddress	In	unsigned int	Modbus Address of device
4	nciCommsConfig	In	SCommsConfig	Serial Port Configuration
5,6	NvoUnitSettings[2]	Out	UNVT_Unit_Settings	Unit settings data
7,8	NvoQuery[2]	Out	unsigned int	Indoor data query index
9	nvoClearance	Out	unsigned int	Fault clearance command
10,11	NviIndoorData[2]	In	UNVT_Indoor_Data	Indoor unit data

The LTX-51 is a gateway used for transferring significant amounts of data between the BMS and the air-conditioning system. As such the functionality of the gateway is very different from a standard LonWorks device. The gateway uses several user defined network variables to allow compatibility with target devices such as the Toshiba LG1. Data is transferred to the air-conditioning interface using the nvoUnitSettings data structure. One field in this data structure is the address of the target indoor unit, the rest of the data fields contain all of the necessary variables required to completely define the operation of the unit. To read-back data from the units, the nvoQuery network variable is set to a particular unit address, the air-conditioning interface responds by writing its current state to the nviIndoorData. Again this contains an address field to identify the source address of the data.

The LTX-Modbus Engineering Manual documents the core Network Variables in the LTX

LTX-51 Application Network Variables

network output UNVT_Unit_Settings nvoUnitSettings

User defined data structure with the following fields

```
typedef struct {
    unsigned int    unit_number;
    SNVT_hvac_mode hvac_mode;
    SNVT_temp_p    setpoint;
    unsigned int    on_off;
    unsigned int    fan_speed;
    unsigned int    louver;
    unsigned int    filter_reset;
    unsigned int    priority_c_o;
    unsigned int    operation_ban;
} UNVT_Unit_Settings;
```

Valid values for these fields are as follows

Field	Valid Values
unit_number	1..16
hvac_mode	{AUTO=0, HEAT=1, COOL=3, FAN ONLY=9}
setpoint	18.00-29.00 Degrees Centigrade
on_off	{OFF=0, ON=1}
fan_speed	{AUTO=0, LOW=1, MEDIUM=2, HIGH=3}
louver	{OFF=0, ON=1}
filter_reset	{NORMAL=0, RESET=1}
priority_c_o	{REMOTE=0, CENTRE=1}
operation_ban	{NONE=0, PRESENT=1}

This data structure contains the complete operation commands for a single air-conditioning unit, addressed by the field `.unit_number`.

network output unsigned int nvoQuery

Output range is between 1 and 16 and corresponds to the current unit address being queried

network output unsigned int nvoClearance

Propagates a unit reset command to the attached LG1s when the clearance command is selected.

network input UNVT_Indoor_Data nvilIndoorData

User defined data structure with the following fields

```
typedef struct {
    unsigned int    unit_number;
    SNVT_hvac_mode hvac_mode;
    SNVT_temp_p    setpoint;
    unsigned int    on_off;
    unsigned int    fan_speed;
    unsigned int    louver;
    unsigned int    filter_state;
    SNVT_temp_p    indoor_temp;
    SNVT_temp_p    heat_exch_temp;
    unsigned int    unit_fault;
} UNVT_Indoor_Data;
```

Valid values for these fields are as follows

Field	Valid Values
unit_number	1..16
hvac_mode	{AUTO=0, HEAT=1, COOL=3, FAN ONLY=9}
setpoint	18.00-29.00 Degrees Centigrade
on_off	{OFF=0, ON=1}
fan_speed	{AUTO=0, LOW=1, MEDIUM=2, HIGH=3}
louver	{OFF=0, ON=1}
filter_state	{OK=0,DIRTY=1}
indoor_temp	-255.00..255.00
heat_exch_temp	-255.00..255.00
unit_fault	1..255, 0 indicates no unit

The data is returned from the indoor unit and indicates its current operating state.

Configuration Parameters

The LTX-51 has a series of internal configuration parameters stored in EEPROM that retain all of the addressing settings of the device. At present these are not designed to be directly edited via LonWorks engineering tools. Instead they are accessed through Modbus engineering commands. This is a safe access method that ensures that only valid values are set.

The LonWorks engineering tool used should have the capability for uploading and downloading configuration parameters. After the device has been engineered the configuration parameters should be uploaded from the device (e.g using the command "Resync CPs" in LonMaker and selecting *Upload from device*). If the device needs to be replaced in the future or the database is duplicated for another site, these values will be installed in the new device.

7 Toshiba Installation and Commissioning

1) All units (if possible) should be placed on the X-Y network. B-C Slave wiring should NOT be used

2) The X-Y network should be wired as a daisy chain from the panel where the LG1 is located to each unit. Multiple cables should not be run out from the panel, refer to Toshiba instructions for more details.

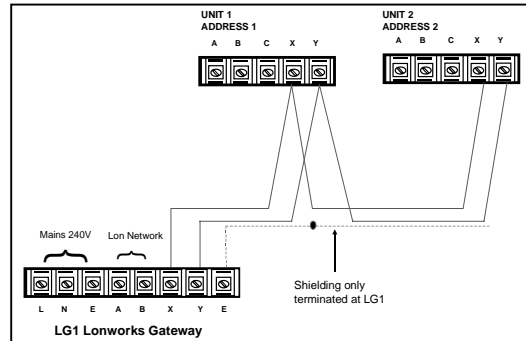

3) If more than 16 units are installed, then the units should be divided into groups of 16 or less and each group wired and addressed separately. An LG1 interface (and LTX) is required for every 16 units

4) If remote controllers are used, they should only be wired to the MASTER via ABC, The slave BC connection should NOT be installed if the slaves are on the X-Y network. Slave control is performed by the BMS.

5) All units on X-Y network should be setup with SW01 rotary switch set to 1. All units are 'masters' on the X-Y. Slave groups are created in software. SW02 should be set to the unit number using the following dip switch settings. **Note that the indoor board must be re-powered for this addressing to take effect.**

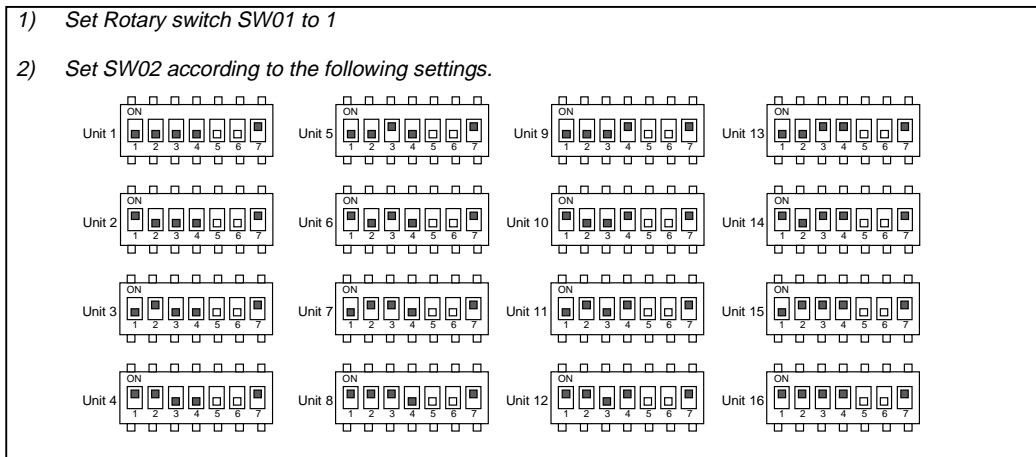

6) To commission the system, instead of using a remote controller the network should be commissioned using a Central Controller available from Toshiba. This works on the X-Y network and will confirm that the unit addresses are set up correctly. It allows units to be individually run and shows the fault code status for each unit.

7) **Once the system is commissioned , the X-Y network cable can be simply transferred from the central controller to the Toshiba LG1.** Refer to the Toshiba LG1 installation instructions for further details of X-Y network wiring and DIP switch settings for address allocation.

LTX-51 ISS1.00

8 Summary of Toshiba Fault Codes

Below is a brief summary of the Alarm codes that can be generate by the Toshiba units. Refer to the Toshiba Service manual for more detailed explanations of the codes.

Hex Code	Fault	Critical	Decimal Code
00	No indoor unit connected	x	0
04	No communication on 1-2-3 terminals	✓	4
08	Reverse temperature change	x	8
09	Frost or no-temp change	x	9
0B	Indoor unit float switch	x	11
0C	Indoor temperature sensor TA	✓	12
0D	Indoor heat-exchanger sensor TC	✓	13
12	Indoor microprocessor fault	✓	18
14	Refer to outdoor unit (Super Multi)	✓	20
15	Refer to Multi Controller	✓	21
18	Refer to outdoor unit (TE Sensor Fault)	✓	24
19	Refer to outdoor unit (TL/TD Sensor Fault)	✓	25
1C	Refer to outdoor unit (Super Multi)	✓	28
1D	Refer to outdoor unit (Super Multi)	✓	29
1E	Refer to outdoor unit (High discharge temp)	✓	30
1F	Refer to outdoor unit (Super Multi)	✓	31
21	Refer to outdoor unit (High pressure switch)	✓	33
99	Lost communications with indoor unit	✓	153
B7	Group Fault Code	✓*	183
FF	No Fault	-	255

* B7 Fault code indicates a fault in one or more slaves attached on the A-B-C network of a master. By default it is assumed that B7 *could* be critical. LTX alarm options defined by R(G) allow B7 faults to be classified as non-critical if so desired.

NOTE: There only difference between decimal and hexadecimal is the way the number is displayed. When viewing fault codes from the LG1 the data may be formatted in either hexadecimal or decimal format, depending on what viewing method is used. To maintain compatibility with established fault code methods these codes should always be formatted and displayed in *hexadecimal*.

9 Installation Instructions

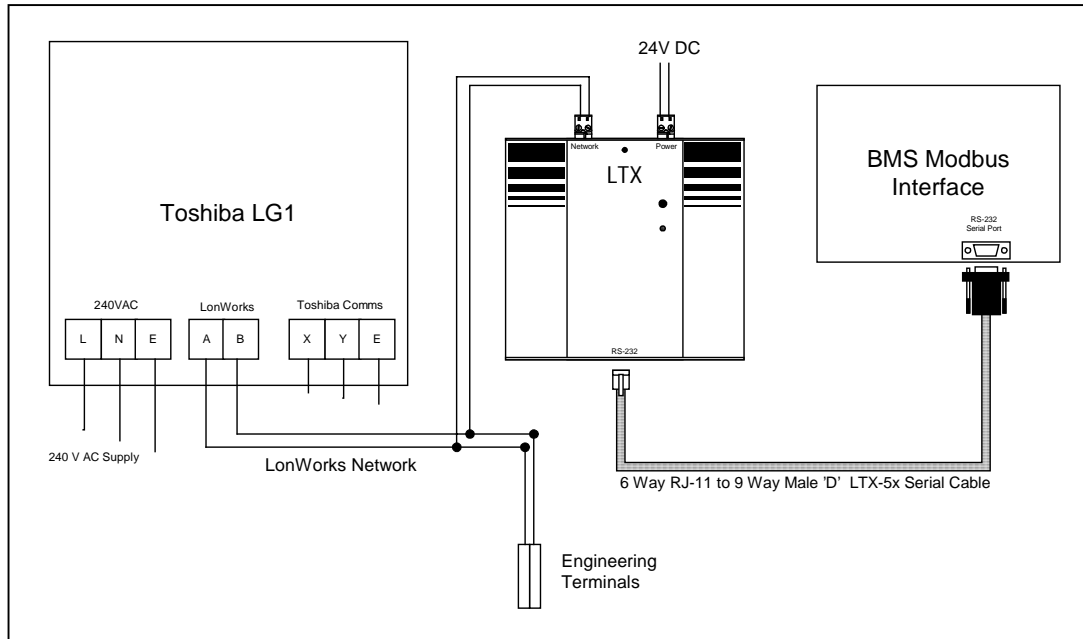

The LTX is connected as shown in the above diagram.

- 1) Mount the LTX on a standard symmetric DIN rail. A clearance of 85mm above and 105mm below the DIN rail centreline should be allowed and 155mm horizontal clearance. See the figure to the right.
- 2) Connect the LTX Power connector (black) to a 1.5VA 24Vdc supply. The connection is polarity independent. Do not power the device up.
- 3) Install the LonWorks network between the LTX connector labelled 'Network' (orange or green) and the LG1 terminals labelled 'A-B LonWorks' using unshielded twisted pair; the connection is polarity independent. Multiple devices can be daisy-chained.
- 4) Daisy-chain the LonWorks connection from the LTX to a pair of screw-terminals mounted on the DIN rail adjacent to the LTX. This is for engineering purposes and allows easy access to the network.
- 5) Daisy chain a network terminator to the LonWorks network if specified.
- 6) Connect the supplied grey RJ-11 to 9 Way Male 'D' cable between the LTX port labelled 'RS-232' and the BMS port used for Modbus interfacing.

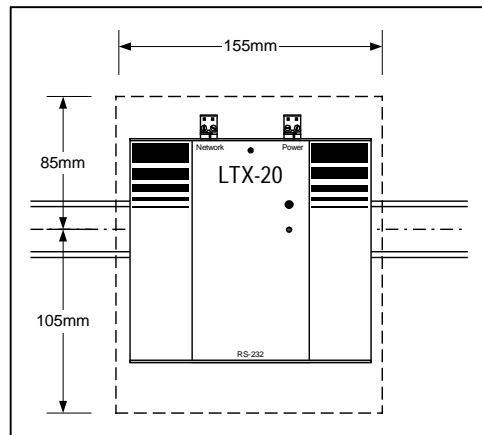

LTX-51 ISS1.00

10 Troubleshooting Guide

Problem	Cause	Actions/Checks
LTX not communicating with the Remote Outstation	Incorrect Comms Parameters	Change the communications parameters of either the LTX or the connecting BMS to match
	Incorrect Modbus Address	Assign a valid Modbus address to the LTX using the LonWorks configuration NV or via a Modbus engineering tool
Unit in 99 Fault	Unit not responding to queries	Check X-Y network Installed correctly
		Check indoor boards addressed correctly
		Check Rotary switch SW01 set to 1.
		Check for duplicated unit addresses on SW02
		Check units re-powered after re addressing
Unit readback settings are different from those sent by LTX	Unit not able to achieve required operating conditions	Check if louver activation is called for on a unit without louvers – or the louver jumper CN21 has been removed
		Heating is being called on a cooling only unit.
		The unit has a local hold-off device such as a Toshiba T2
		Check Rotary switch SW01 set to 1.

11 Technical Specification

Electrical

Supply	24V DC unisolated
Power	1.5VA
Processor	Echelon 3150
Clock Speed	10 MHz
External Memory	32kb PROM, 24kb SRAM
LON Network	FTT-10A Transceiver, Free topology network
RS-232	9k6 baud, max cable length 3 metres. Use cable LT-CC-1 supplied

Mechanical

Dimensions	H138 x W146 x D38 without DIN clip H144 x W146 x D48 with DIN clip
Mounting	Quick release standard DIN rail
Clearance around DIN rail	Minimum 85mm above and 105mm below DIN rail centreline
Casing Material	Casing – Powder coated 18 gauge steel to RAL 3020
Weight	250g
Power and LON Connectors	Two part rising clamp 0.5mm" to 2.5mm" cross sectional area cable
RS-232 Connector	RJ-11 Socket

Environmental

Temperature	
Storage	-10oC to 50oC
Operation	0oC to 50oC
Humidity	0-90% RH non-condensing
Protection	IP30
EMC Emissions	EN50081-1
EMC Immunity	EN50082-1

Future updates of this datasheet available from <http://www.realtime-controls.co.uk>